

Installation Instruction

User Guides



E-LOCK-WD-M

I. Description

1.1 Overview

Our wired electronic lock is a smart lock device designed for motor-controlled doors. This electronic lock uses a precise control mechanism and perfectly cooperates with the door and motor to provide a convenient and safe door locking solution.

1.2 Features and Advantages

Safe and reliable: The electronic lock is linked with the motor to ensure that the door is effectively locked when closed to prevent illegal intrusion.

Wired connection: Stable and reliable wired connection avoids wireless signal interference and the trouble of battery replacement, ensuring long-term stable operation.

High compatibility: Compatible with most electric door systems on the market, easy to install and does not require complex modifications.

Sturdy and durable: Made of high-strength materials, resistant to impact and corrosion, and suitable for various environmental conditions.

1.3 Scenarios of Use

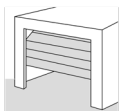

Sectional doors

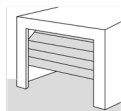

Tilting doors

II. Features and Technical Data

2.1 Features

- The E-LOCK-WD works automatically with garage door opener and Industrial door openers. it always locks and unlocks with every operation of the door.
- An extra security guarantee for garage and industrial doors.

2.2 Technical Data

Model	E-LOCK-WD-M
Electronic lock input voltage	10-38V DC
Trigger power consumption	400mW
Uncaging time	0.5s
IP grade	IP 43
Operating temperature:	-20°C - + 60°C

III. Product Composition Display

3.1 Introduction to Components

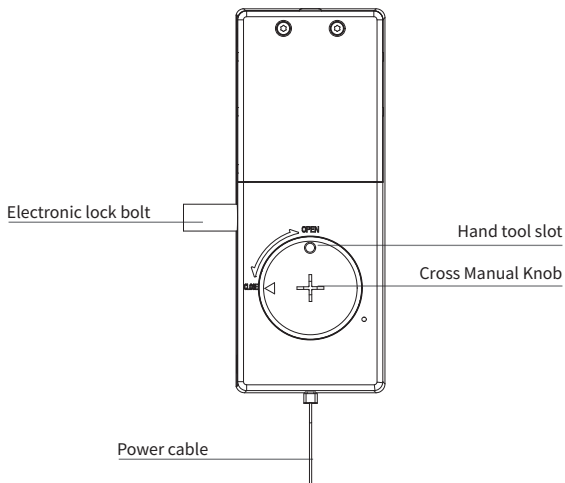

3.2 Manual Knob Test

Use a phillips screwdriver to turn, or put the screwdriver in the Hand tool slot and turn it.

Check whether the rotation and lock bolt are working properly and smoothly.

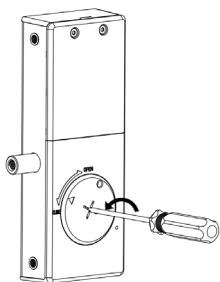

Turn with phillips screwdriver

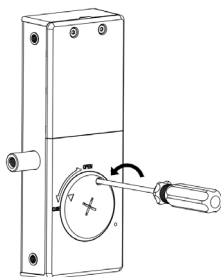

Turn with hand tool slot

IV. Installation and Configuration

4.1 Tools

For a quick and safe installation of the E-lock, the following tools are recommended:



Pistol drill



Tape measure



Screwdriver



Pencil

4.2 Installation Steps and Operating Instructions

4.2.1 Before installation, please perform the tests first to avoid any inconvenience

- Connection with the motor
- Function test to ensure the E-lock works properly with motor.

— Step Instructions:

A. Connect the electronic lock to the Wired E-LOCK port of the motor.

Electronic lock "+" connect to Realy module "+"

Electronic lock "-" connect to Realy module "-"

B. Wiring and set up of Wired E-LOCK with GDO PRO.

B.1 GDO PRO wiring with E-LOCK-WD

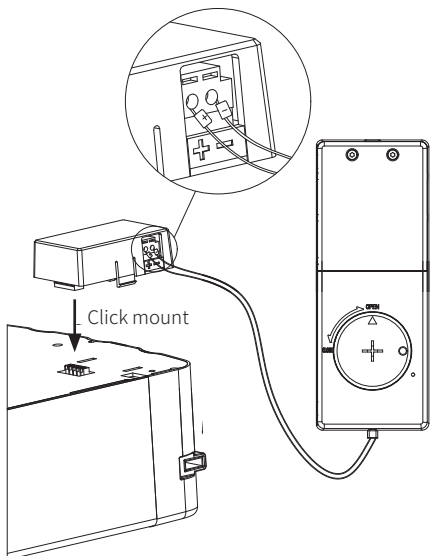

B.2 Activate the Wired E-LOCK function on GDO

Note: Please select the setting method according to the operation in the motor manual

B.2.1 Setting method of the multiple function opener



1. Press and hold SET Button until "1" appears on the display, next press the UP button until "P" appears on the display to enter the wired E-Lock function setting, then release the button.

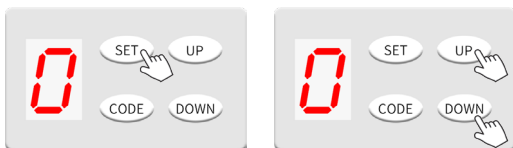

2. Press the SET button again. The motor is now in the wired E-Lock function mode. And then you will see a figure "0" appears on the display.

3. Press the UP/DOWN button once to set the indication number to "1", then the wired E-Lock function is enabled.

Number "0" : The wired E-Lock function is disabled.

Number "1" : The wired E-Lock function is enabled.

NOTE: Factory default is set on "0" as standard.

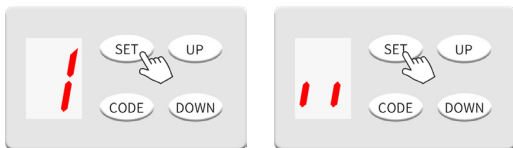

4. Press SET button to confirm the set and it will be back to standby status automatically and display "11".

B.2.2 Setting method of the basic function opener.

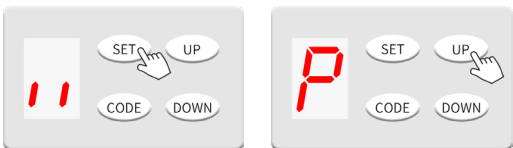

Press and hold the SET button until "P" appears on the display then release the button. The motor is now in the wired E-Lock function mode. And then you will see a figure "0" appears on the display.

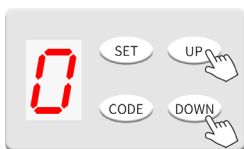
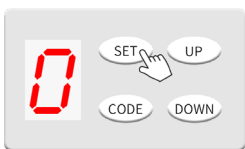

2. Press the UP/DOWN button once to set the indication number to "1", then the wired E-Lock function is enabled.

Number "0" : The wired E-Lock function is disabled.

Number "1" : The wired E-Lock function is enabled.

NOTE: Factory default is set on "0" as standard.

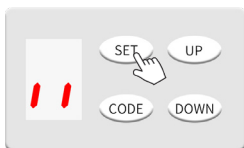
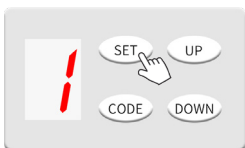

3. Press SET button to confirm the set and it will be back to standby status automatically and display "11".

C. Wiring and set up of Wired E-LOCK with Multi-drive.

C.1 Multi-drive wiring with E-LOCK-WD

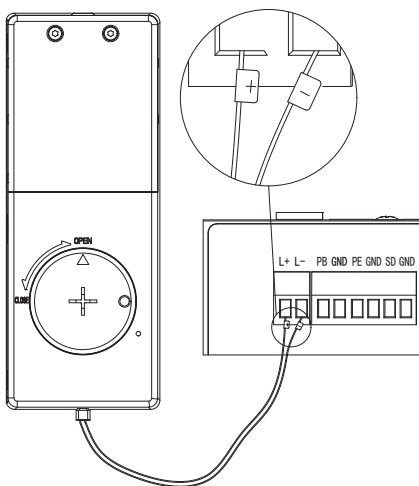

C.2 Activate the Wired E-LOCK function on Multi-drive

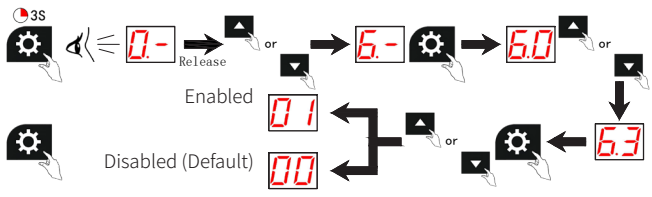

Note: For detailed function description, please refer to the corresponding motor manual.

Test the motor function, confirm that the electronic lock function is turned on,

- When the door is fully closed, try to open the door by the motor, electronic lock bolt will retract firstly and automatically, then the door will start opening.
- When the door is fully opened, try to close the door by the motor, the door will start closing, then electronic lock bolt will extend automatically when the door is fully closed.

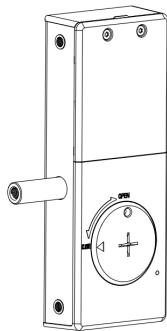
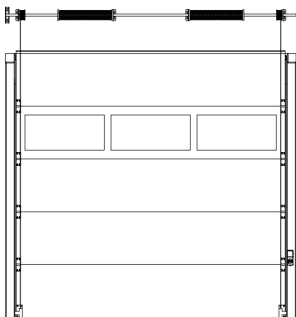

Note:

1. Rotate the knob to check if the extension and retraction of the lock bolt is blocked. If it is blocked, please check the hole position installation and make adjustments.
2. If the electronic lock does not move or the lock bolt moves in the opposite direction to the above, please check the "+" "-" wiring connection between the motor relay and E-LOCK.

4.2.2 Installation

Step A

Make sure the garage door is in the close position.

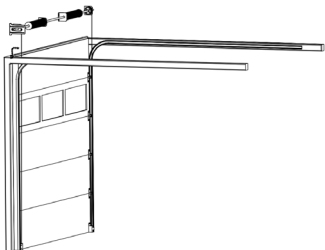

Step B

Use the position label to confirm the installation location of the E-lock. It is recommended that the lock bolt of the electronic lock is located 5-10cm above the roller in the track.

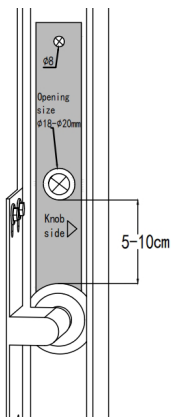

Step C

Open the garage door to the open position.

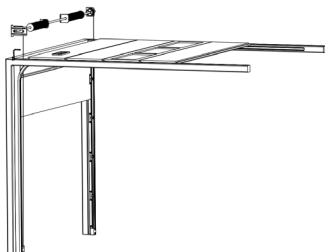

Step D

Drill holes according to the diameter size indicated on the hole positioning sticker.

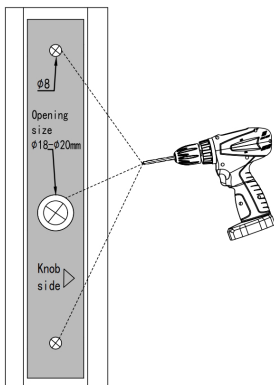

Step E

Use screws to secure the E-Lock device in place.

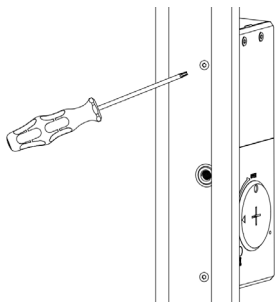

Step F

Installation is complete.

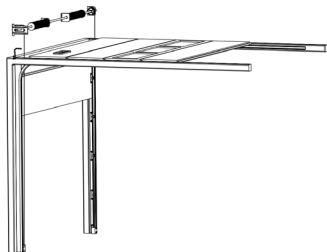

4.2.3 Test Mechanical Operation

Turn the knob to check whether the lock bolt can be extended and retracted properly.

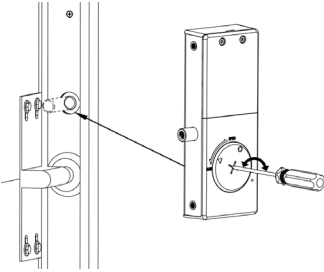

Use the knob to retract the lock bolt and check if there is any obstruction.

Use the knob to extend the lock bolt and check if there is any obstruction.

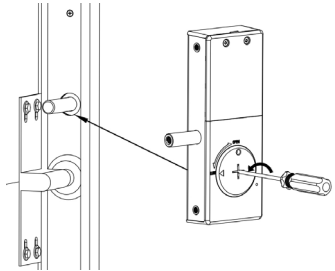
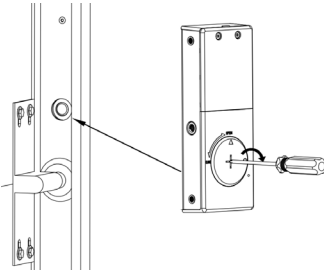

Note:

1. Rotate the knob to check if the extension and retraction of the lock bolt is blocked. If it is blocked, please check the hole position installation and make adjustments

2. If the electronic lock does not move or the lock bolt moves in the opposite direction to the above, please check the "+" "-" wiring connection between the motor relay and E-LOCK.

4.3 Actual closing test

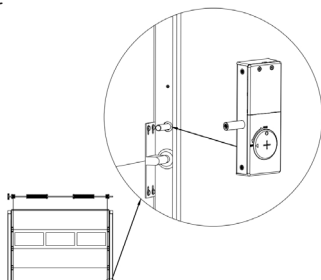

When the door is closed to the close limit position, the lock bolt will automatically extend and lock in the track. But if you want to start opening the door, the lock bolt will automatically retract firstly, and then the door will perform this open action.

Note: Please make sure no operation of electronic lock knob manually during the door opening or closing.

VI. Appendix

6.1 Packing List

Description	Qty
Positioning sticker	1
Wired E-Lock	1
Relay module	1
M6*8mm screw	2
Manual	1
Extension rod	Optional

6.2 Dimensions

Unit of Length: mm

